



CELLSCALE®₉₀₀₀

CELLULAR WEIGHING FROM MSI

MSI-3750CS RF Digital Weight Indicator • Product Specifications

A stellar solution for industrial weighing and process control

Hardware Overview

Electronics

- μ C Board: 4 layer SMD, H8-536 based
- Power Supply: 85-265 VAC, 47-440 Hz/130-300 VDC
- Highly integrated radio modem: 2.4 GHz spread spectrum. Available with 2 antenna options
- 1 Comm port, RS-232, Baud rates to 38.4k
- Option for set points: 7 Isolated internal relays (1A 125 VAC, 2A 30 VDC) and 1 non-isolated logic output
- Backlit LCD, visible in sunlight

Housing

- Alodined and powder coated cast aluminum. O-ring gasketed. NEMA 4, IP65

Specifications

Temperature

- 20° C to +60° C Operating (-4° F to +140° F)
- 40° C to +80° C Storage (-40° F to +176° F)

Approvals (pending)

NTEP, OIML, CE.

Radio Link

Frequency hopping spread spectrum in 32 channels @ 2.4 GHz. Allows 32 networks of multiple scales. Radio functions in the ISM band, license free in the USA and Europe. 10mW (low power) or 100mW (high power) average output.

Radio Link Effective Range

Typically 150m (500') indoors, 300m (1000') outdoors with standard antenna.

RFI/EMI Shielding

Exceeds NIST HB44 and CE Standards.

Weight

2.8 kg (6.2 lb.).

Standard Features

Scale Monitoring

The MSI-3750CS can log on to any active CellScale network and can be programmed to switch networks with a single key press.

Calibration

Via RF, the MSI-3750CS can calibrate any CellScale system. Sealing of the system occurs at the CellScale.

Keypad

23 keys – 5 user programmable, 10 key alphanumeric, and 8 control keys.

Pushbutton Functions

Fixed keys:

Power: On/Off.

Zero: Removes weight on scale.

Net/Gross: Switches between Net and Gross weights.

Tare: Removes container weight and switches to Net mode.

Print: Output user configurable print strings to Comm Port.

Alpha: Allows alpha character entry of upper and lower case.

Enter: Store parameters or enter menus.

Setup: Setup scale functions.

0-9: With alpha characters.

Function Keys: 5 function keys are settable to any of the following functions:

Total: Add the current weight to the total or Auto Total On/Off.

Grand Total: Display totaled weight of all ID Codes.

Statistics: Prints statistics of current ID Code.

View Σ : Displays totaled weight of the current ID.

ID#: Push to change the ID code.

Set Points: Set and configure set points.

Units: Change weight units.

Modem: Configure RF Modem.

RF Network: Set Network parameters.

SC Index: Switch between selected scale channels.

Clear Latch: Used to clear latched set points.

Peak Hold: Captures maximum readings.

String 1 and String 2: Displays user configured print strings associated with each ID.

Test: Performs LCD display test.

Programmable Features

- Automatic or Manual Tare entry.
- 32 Set points with messaging capability (7 local relay outputs) stored in CellScale.
- Peak Hold: for capturing maximum readings.
- 32 programmable ID codes.
- Backlight On, Off or Automatic.
- Lock: The user can lock any or all features to prevent tampering with setups. Protected by password.
- RS-232 option will output on demand, on a change, on a load, on a set point, on Total, by computer control or continuously with

programmable time interval.

- RS-232 I/O provides full output formatting to interface with computers, printers, scoreboards and most serial devices

Display

- 6 digit 23mm (.9") numeric weight LC display
- 8 digit 11mm (.45") alphanumeric LC display (message/units/total weight)
- 21 Segment bar graph for process control percentage indication or RF activity
- Annunciators for measurement modes
- Sunlight visible LED indicator for Totals, Set Points 1 and 2
- Photocell activated fiber-optic LED backlighting

Calibration Parameters

See CellScale specifications. All calibration data is stored in the CellScale, allowing any MSI-3750CS to use any CellScale based system without recalibration.

Real Time Clock

Supports date/time stamping in USA or European formats. Backed up by a replaceable Lithium Battery (Typical life >5 years).

Data I/O

1 Comm Port, RS-232. Baud Rates: 300, 600, 1200, 2400, 4800, 9600, 19.2k, 38.4k. CTS/RTS handshaking and software handshaking.

ID

Up to 32 product IDs can be stored in any connected CellScales and are identified by Alphanumeric ID names. Each ID stores Totals, Statistics, Tare values and two 20 byte string messages.

Totalization & Statistics

Stored in the MSI-9000 CellScales, displayed on the MSI-3750CS (Function Key or Automatic). Weight totals up to 999,999,999. Weighments's counter up to 65,535. Totals and statistics are stored with each ID register. Each ID code retains full statistics on totaled weighments (Standard Deviation, Minimum, Maximum, Average and Coefficient of Variance). Statistics are available through Comm port only.

Connectors

Power and Comm connections are made with heavy duty waterproof industrial connectors. Antenna connector is standard TNC. Set Points internally wired with cables sealed through water tight feedthrough connectors.



Measurement Systems International

Options and Accessories

Optional Power Supply

- 10-36 VDC
- 20-60 VDC

Set Point Relays

The Set Point Relays provide up to 8 set point outputs for interfacing to external devices such as warning lights, process relays, or sirens. 7 SPDT (form C) 1A/115 VAC relays are provided internal to the MSI-3750CS meter for direct set point interfacing. The 8th output is a TTL compatible logic output. Connections

are made through waterproof feedthrough connectors to terminal blocks. Set points are controlled by the CellScale set points 1-8.

External Totalize Switch with Audible Alarm

A transient protected switch input with connector for remote totalizing. Normally open momentary switch is supplied by the end user. Coupled with the internal set points, an alarm can sound at any weight. Can also be used for accept or an out-of-limits indicator for blind check weighing. Supplied with 4m (13') cable.

Long Range Antennas

Optional long range antennas available for applications requiring transmission range >300m (1000') up to 16km (10 miles).

Mounting Bracket

For wall or bulkhead mounting with 180° swing.

Serial Cable

RS-232, 4m (13') interface cable with standard DB-9 serial connector (longer lengths available by special order).

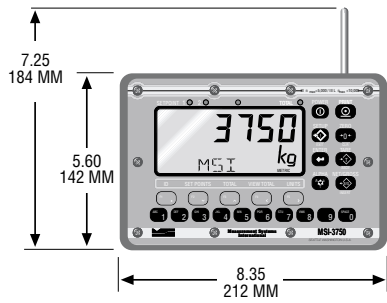

3750CS DIMENSIONS

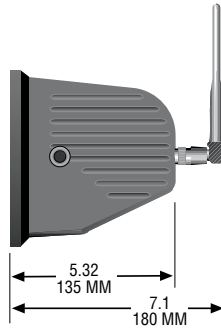

DESKTOP VIEWING POSITION

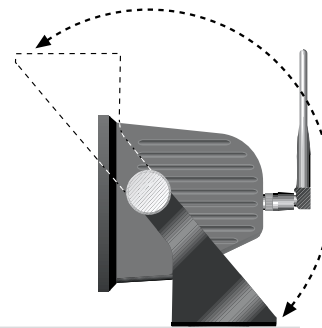
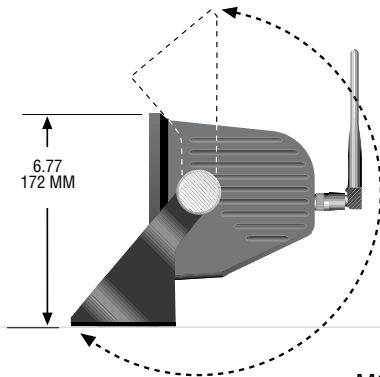

MOUNTING BRACKET POSITIONS



Specifications subject to change without notice.

PUB.256-03-00E Printed in U.S.A.
© 2003 by Measurement Systems International, Inc.
CellScale® is a registered trademark of Measurement Systems International, Inc.

